



**KarbenTec**



*SMART LOCK  
6011*

**The future hotel's best choice**

**The smart replacement of existing magnetic card system**



The 6011 RFID hotel lock is thus equipped with a built-in alarm, which is activated when the door is not properly closed.

And this smart door lock system has open the door, get power, parking, access control, lift controller, consumption, such as IC card function, for the customer and hotel management to bring real, great convenience .

The 6011 RFID hotel lock is beneficial in its acquisition when compared to many other locks, while it is a high quality. From materials ,chips, Surface process,etc.

# Hk6011

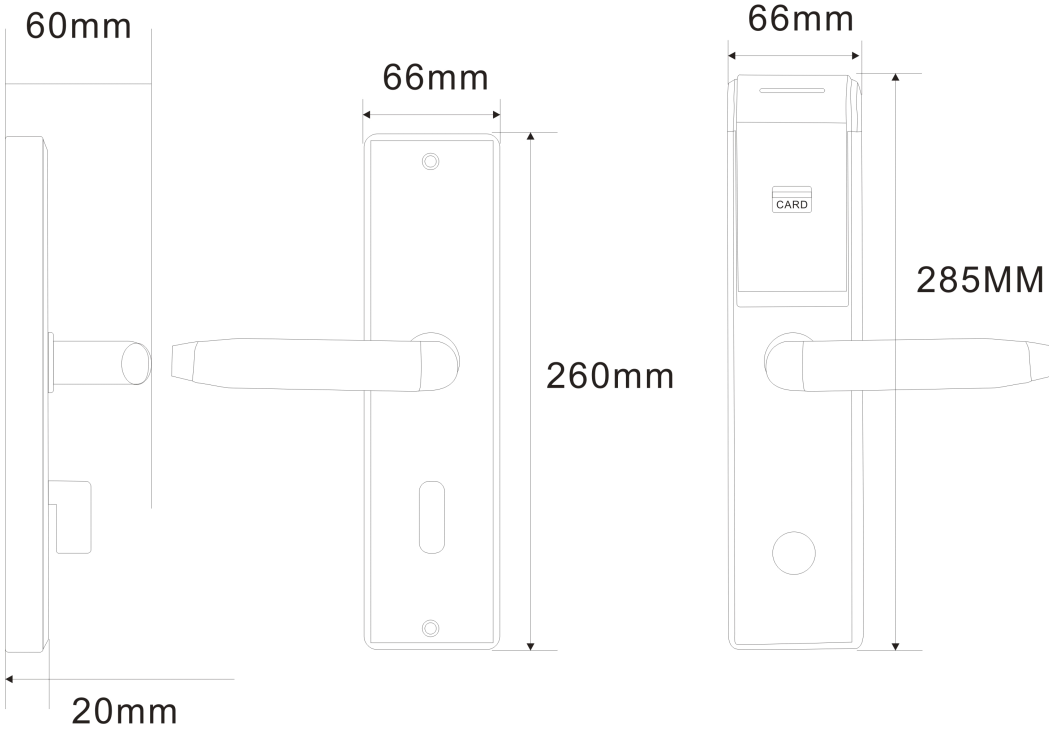
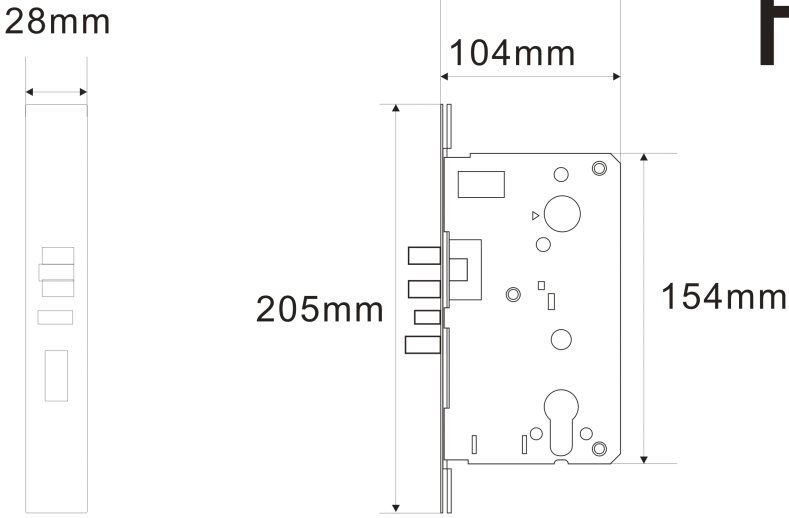

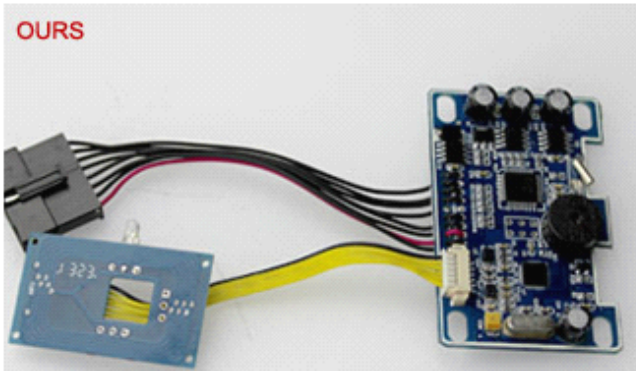

**Pcb board:Independent clock chip  
MF chip never loss information**

**VS**  
**1**

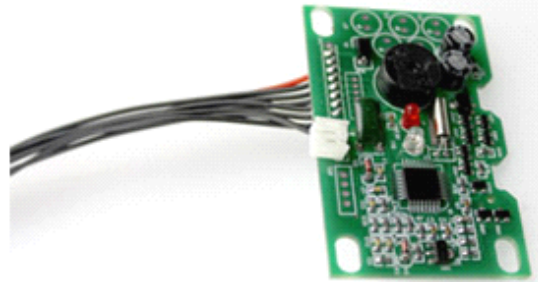

**Pcb board:no Independent clock chip  
MF chip often loss information**

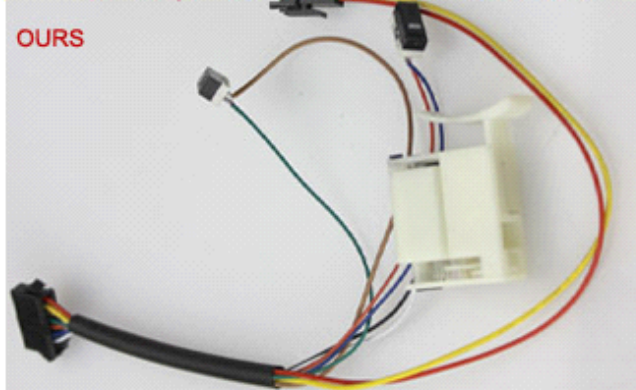

**Motor:Imported from Japan Mabuchi  
Stable performance, reliable**

**VS**  
**2**

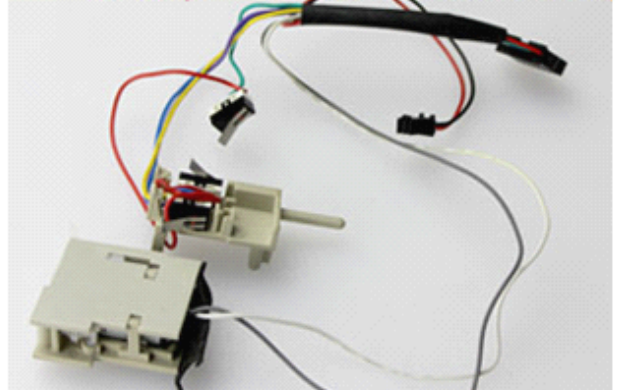

**Motor was made in China  
It has poor road-holding in wet conditions**



**Europe Machine key:install very easy  
Improve work efficiency**

**VS**  
**3**



**ANSI Machine key:need screws fixed  
behind the mortise,very difficult**

The 6011 RFID hotel lock is equipped with durable contactless card technology, which is insensitive to scratches and magnetic fields. The battery has a high longevity (normal 4pcs AA batteries can use 14 months) and both the locks and cards are low-maintenance. The locks are standard equipped with an emergency cylinder and a special fire prevention card to keep the doors open during an emergency.



*Durable contactless card technology.  
Which is insensitive to magnetic fields and scratches.etc.  
Assembly in Holland,100% own development  
High quality card slot built from  
304 STAINLESS STEEL Components.  
No wear and tear to lock and cards,low  
maintenance.  
Internal memory readout last 830 lock  
opening records.  
Card has extended function, can be used for  
parking, consumption, lift control*

### *Main technical data*

- In accordance with EN14846 standards.*
- Lock without a cable, current using 4 x standard AA batteries incl. low battery voltage alarm.*
- Longevity of batteries minimum 14 months.*
- Emergency cylinder and mechanical key to open the door in case of emergency.*
- Electronic mortise, with anti-panic function and dead bolt lock.*
- The lock draws the attention of the guest with a subtle alarm if the door is not properly closed.*
- Once the lock is bolted on the inside by the guest, it is visible through the red glowing LED (privacy function).*
- Optionally available with wall readers for control of electric doors and/or locks.*
- Optionally available with intelligent energy control units for switching current in the hotel room.*



The 6011 RFID HOTEL LOCK has got Intertek En14846 certification.





*Karben Tec provides safety- and comfort products for every segment of the hotel industry. However, this does not only pertain to the supplying of products.*

*Karben Tec has its own Research & Development department where innovative products are developed and produced. Quality and competitive pricing take precedence, while sustainability and care for the environment do not get ignored. Karben Tec is the market leader in the Benelux countries and has a global service network.*

*We see to the transport, delivery and assembly ourselves. This enables us to offer you the best possible products and service. We have sales channels in a lot of countries around the world and tourism cities. Discover what Karben Tec can do for you business on [www.Karben Tec.com](http://www.Karben Tec.com)*



hotel lock

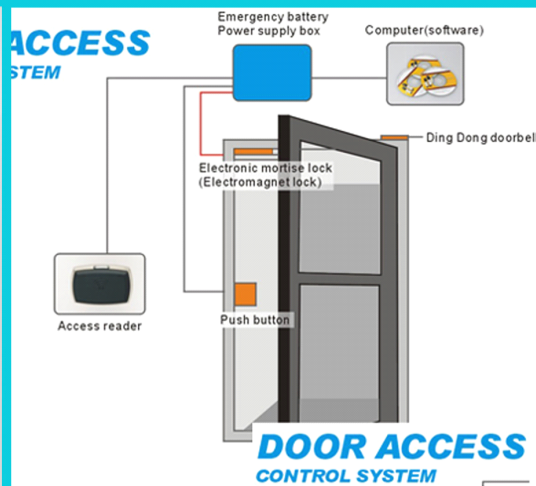

door access



lift controller

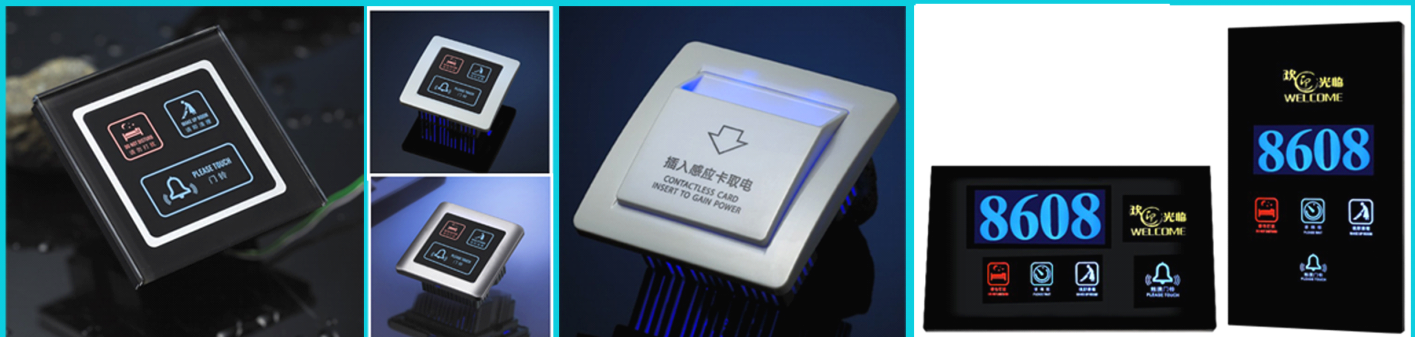

smart DND switches system